

Picture 1

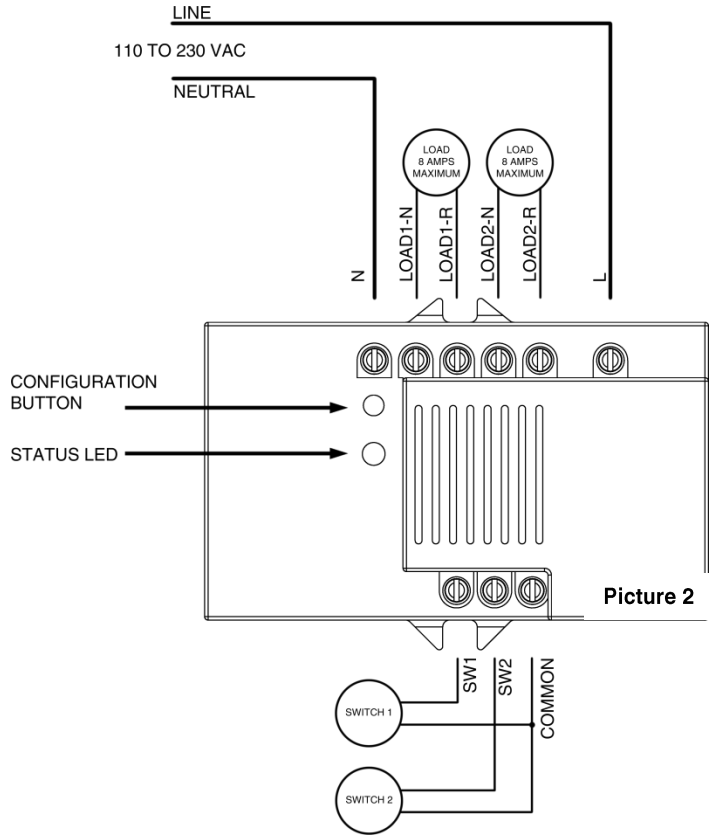

Picture 2

DANGER! SHOCK HAZARD



NOTE: This module must be included in the Network only where it will be permanently installed. The proper operation of this node in the mesh network is dependent on it knowing its location with respect to other nodes. You cannot "test bench" configure this module.

BASIC OPERATION

LED Indication

- **Blinking non uniformly:** The device is not within a network.
- **Blinking uniformly:** The device has opened the joining window to add more devices through it.
- **Always On:** The device is within a network.

Internal Circuit Protection

The SW1010 internal circuitry is protected by an internal fuse. This internal fuse is factory serviceable only. Check your home circuit breakers before concluding that the product must be returned to manufacturer for repair at a nominal charge.

INSTALLATION

Wire this Module behind of a current wall switch according to the diagram above (See Picture 2).

Terminal Description:

- **F:** Line (Live)
- **N:** Neutral
- **LOAD1-N:** Neutral of load 1
- **LOAD1-R:** Return of load 1
- **LOAD2-N:** Neutral of load 2
- **LOAD2-R:** Return of load 2
- **SW1:** Wire of switch 1
- **SW2:** Wire of switch 2
- **COM:** Common wire between switches

LINKING SW1000 TO THE NETWORK

STEP 1. Open the joining window pressing "Add device" button on Smartee App. Once pressed the button, there will be 60 seconds to add any device to the network.

STEP 2. The SW1000 must be in its permanently installed location. The device has to be looking for a network and the Status LED has to blink uniformly. The Status LED will stop blinking and will stay on. If the pairing process was successful, the Status LED will stay on.

UNLINKING SW1000 TO THE NETWORK

Press the Configuration button for 10 seconds and release it. The Status LED will start blinking uniformly.

LINKING ANY DEVICE TO THE NETWORK VIA SW1000

STEP 1. Open the joining window pressing "Add device" button on Smartee App. Once pressed the button, there will be 60 seconds to add any device to the network.

STEP 2. Press the Configuration button of the node (device between Smartee and final device to link) for 5 seconds and release it. The Status LED will start blinking evenly for 60 seconds.

STEP 3. Press the Configuration button of the final device to link for one second and release it. The Status LED will stop blinking and will stay on.

SPECIFICATIONS

Power : 110 to 230 VAC, 50/ 60 Hz

Signal:	(Frequency) 2400 ~ 2480 MHz, 250Kbps capable
Maximum Load:	Resistive: 10 amps (2300 watts @ 230V) maximum, 120 VAC Motor: 1/2 H.P.
Range:	Up to 100 feet line of sight between the Wireless Controller and/or the closest Smartee.
Communication:	Wireless Zigbee HA1.2
Power reading error:	1% - 5%
Humidity:	5% - 95% non-condensing
Up to 2 power outputs	On-Off output

COMPATIBILITY WITH ZigBee® DEVICES HA1.2

The Switchee features out-of-the-box compatibility with any ZigBee HA 1.2-certified hub controller, bridge, or platform.

FCC NOTICE

Note: The Zigbee/Radio/Module has been tested and found to comply with the limits for a Class B digital device, pursuant to part 15 of the FCC Rules. These limits are designed to provide reasonable protection against harmful interference in a residential installation. This equipment generates, uses, and can radiate radio frequency energy and, if not installed and used in accordance with the instructions may cause harmful interference to radio communications. However, there is no guarantee that interference will not occur in a particular installation. If this equipment does cause harmful interference to radio or television reception, which can be determined by turning the equipment off and on, the user is encouraged to try to correct the interference by one or more of the following measures:

- Reorient or relocate the receiving antenna.
- Increase the separation between the equipment and receiver
- Connect the equipment into an outlet on a circuit different from that to which the receiver is connected
- Consult the dealer or an experienced radio/TV technician to help.
- Changes or modifications not expressly approved by the party responsible for compliance could void the user's authority to operate the equipment

SUPPORT

For support, contact us at support@webeelife.com

WARRANTY

12-Month limited warranty on the Switchee On/Off.